

## label design guideline

# eggyplay®

### Die cut specifications

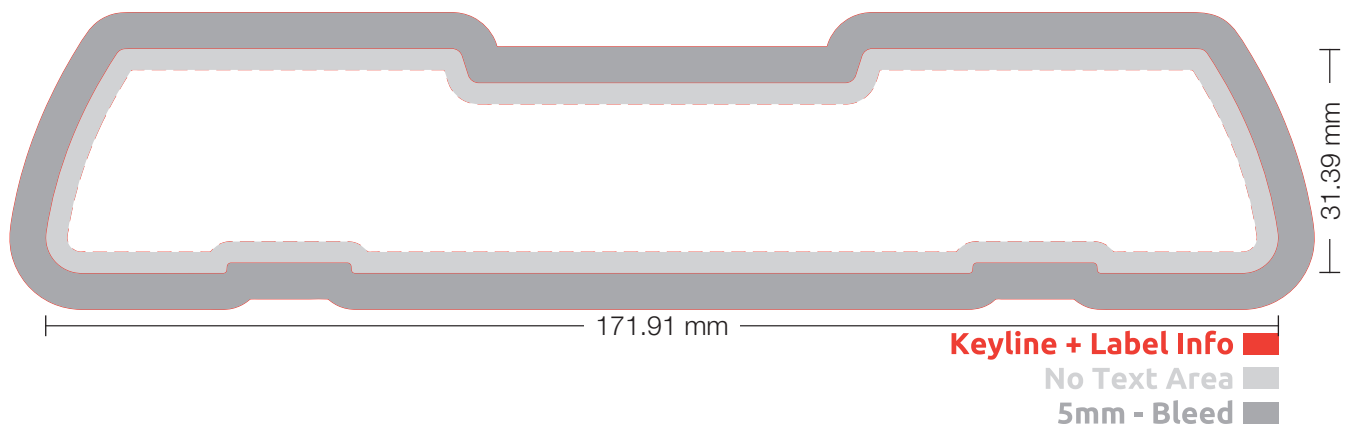

### Standard eggplay® labels



#### Examples, standard eggplay® label

The company logo is typically placed to the left, the eggplay® images and payoff to the right, and the eggplay® logo and the product description (8 eggs sizes M/L) in the middle.

On the top label ('HEDEGAARD'), the image and text used (on the right side of the label illustrates the concept (text meaning '1) collect, 2) build, 3) play').

## Required elements

The *eggyplay*® logo

The logo must not be altered. We recommend positioning the logo here.



The *eggyplay*® arch

We recommend using the blue arch (100 % cyan) as it complements the logo nicely.

## Optional elements

The background

A coloured background or pattern may be applied. We recommend using the pale blue background with eggs. The background colour or pattern must be visually compatible with the standard *eggyplay*® colours:

Blue: 100 % cyan  
Pink: 100 % magenta  
Yellow: CMYK 3-9-100-0  
Green: CMYK 60-0-100-0



## Illustrations/images

Images/illustrations from the eggypay image bank may be used in label designs. Please contact us if you need access to the image bank.



Example, special label with competition teaser



Example, season label



Example, season label

## Fonts

The preferred font is Helvetica neue LT Std (45 Light and 75 Bold). To achieve a more playful look, Hobo Std can be used for the payoff.

## Back label

---

We recommend using a blue background colour (100 % cyan) on the back label with white text.

This remaining space can be used for required information about the product (e.g. nutritional values, company address) according to country specifications. See the example below.



## Restrictions

---

### *Inner margin*

Vital elements must be placed at least 3 mm from the inside of the die cut on both front and back labels. The margin is marked by a dashed line in the label templates.